

WSG



# FORESTRY SORTING GRAPPLE 15/25/30

**WREKO** ®  
FORESTRY INNOVATION

WSG

# FORESTRY SELECTION GRAPPLE 15/25/30

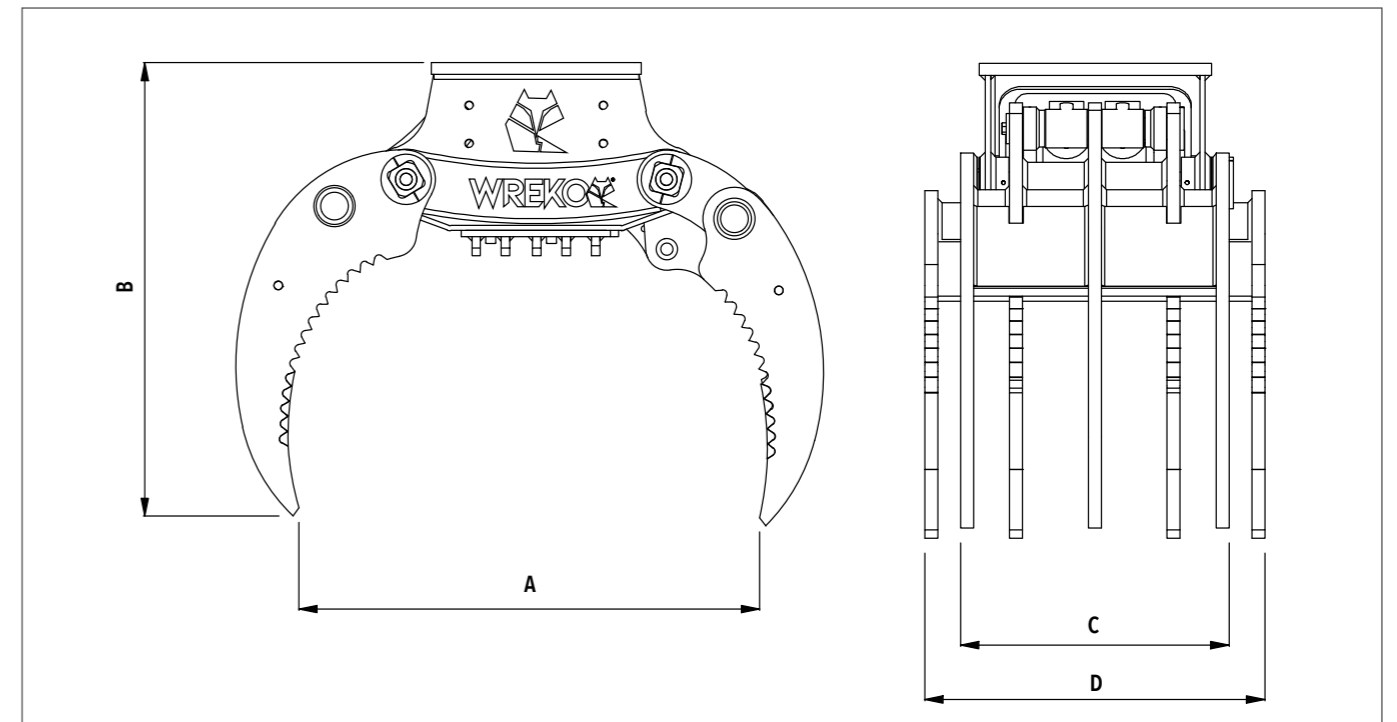

MODEL		WSG15	WSG25	WSG30
Excavator	ton	15 - 25	20 - 30	25 - 40
Weight	kg	610	870	1600
Teeth	n°	4 + 3	4 + 3	4 + 3
A	mm	1096	2000	2400
B	mm	1080	1110	1535
C	mm	620	670	720
D	mm	790	970	1130
Strength	ton	4	7	9
Minimum diameter	mm	90	110	150

The indicated weights are to be considered approximate and refer to the equipment in its standard fixed configuration.

The WSG **Forestry Sorting Grapple** is the ideal tool for forestry operations, particularly **for handling and sorting logs, branches, and other bulky and heavy materials**. It offers precision and versatility in **biomass selection** tasks, minimizing manual effort while increasing operational efficiency.

Its innovative design features grapple tines in a **4+3 comb** configuration, ensuring a secure grip on the material. The tapered tines easily penetrate piles of logs or brush, allowing large volumes of material to be grasped and transported with stability and control. A dual-cylinder system with flanged load-holding valves ensures a firm and reliable grip at all times.

This grapple can be equipped with the **integrated chainsaw unit in the new Wreko cassette, developed with Hultdins technology**, transforming it into a versatile tool also **suitable for felling trees and cutting logs** in forestry applications. The quick coupling/decoupling system, combined with the chainsaw kit, makes the attachment highly flexible and adaptable to different operational needs.

Available in a fixed version or with various hydraulic rotation options.



 **WREKO s.r.l.**  
Via Rovigo, 21  
35042 Este (PD) - Italy

 [wrekosrl@pec.it](mailto:wrekosrl@pec.it)  
P. IVA 05176050283

 +39 0429 1760794

 [info@wreko.com](mailto:info@wreko.com)

#FollowTheFox



[www.wreko.com](http://www.wreko.com)