

WSG



FORESTRY SORTING GRAPPLE 10

WREKO ®
FORESTRY INNOVATION

WSG

FORESTRY SELECTION GRAPPLE 10

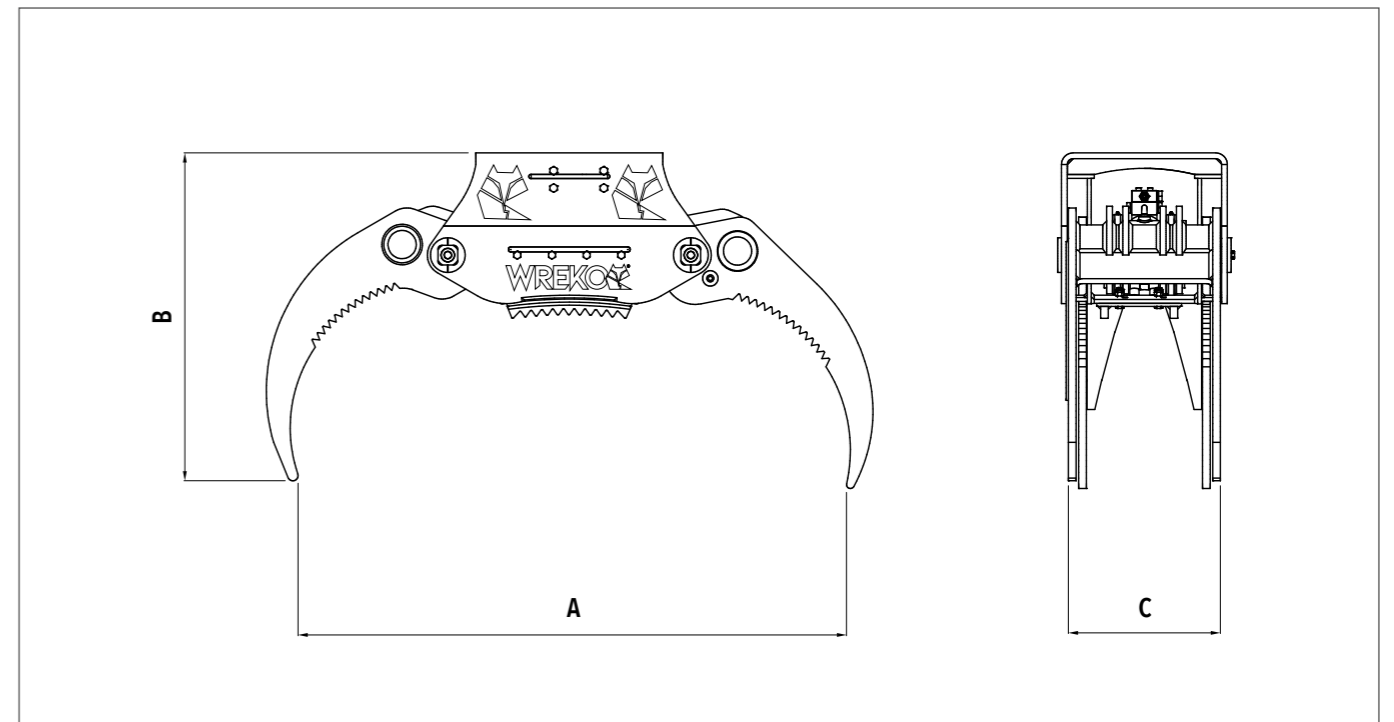

MODEL		WSG10	WSG10 Chainsaw/Rotor
Excavator	ton	8 - 18	12 - 18
Weight	kg	250	860*
A	mm	1420	1420
B	mm	850	850
C	mm	400	400
Capacity	m ²	0,26	0,26
Oil Flow	l/min	50	10
Work pressure	bar	230	175

The indicated weights are to be considered approximate and refer to the equipment in its standard fixed configuration.
*This weight includes the base attachment, the chainsaw, and the rotation.

The WSG10 **Forestry Sorting Grapple**, for excavators from 8 to 18 tons, is a log grapple designed for heavy-duty applications and demanding working conditions. Ideal for **handling and loading timber, brushwood, and processing residues, as well as feeding chippers**, it combines strength, precision, and durability, ensuring high performance even in intensive use.

It can be equipped with the **integrated Wreko chainsaw cassette, developed with Hultdins** technology and redesigned in-house after extensive field testing with professional forestry operators. This solution ensures **greater structural strength during felling, reduced cutting height** for ground-level operation, and **improved protection of components**, increasing safety and efficiency while reducing the risk of unexpected failures.

The **tapered tines** provide a firm and precise grip on the material. The structure, made of high-strength steel, features a reinforced double frame and an oversized cylinder with a flanged load-holding valve, ensuring maximum reliability in intensive work.

The WSG10 is available with a **closed blade, open tips, or 3+2 comb-style tines**, and can be configured as fixed or with different hydraulic rotation options to suit any forestry need.



 **WREKO s.r.l.**
Via Rovigo, 21
35042 Este (PD) - Italy

 wrekosrl@pec.it
P. IVA 05176050283

 +39 0429 1760794

 info@wreko.com

#FollowTheFox



www.wreko.com